

## Rimini Semi-recess Basin XL419C

### Installer layout drawing

**Dimensions:** 460mm x 460mm  
**Colour:** White  
**Taps:** No tap holes  
 Use wall or benchtop taps

**Waste:** Ø32 waste with overflow

#### Installer please note these guidelines.

- Some variations in size will occur with all ceramic products.
- When laying out check first the positions of cabinet draws and all plumbing.
- Double check all dimensions before cutting
- "Take five" before cutting as mistakes can be expensive!
- Trial fit the basin and trim up where necessary.
- Use a bead of approved sanitized silicon to bed in and level the basin on the benchtop.
- Wall fixing bolts are available for commercial or institutional installations.
- We suggest that the delivery carton can be used as a "bench-top" to try-out.

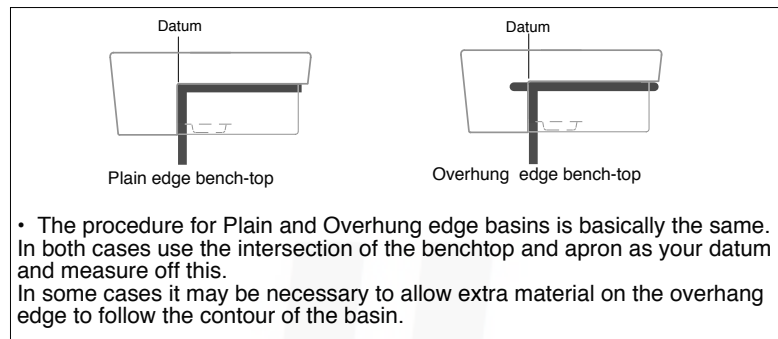

• The procedure for Plain and Overhung edge basins is basically the same. In both cases use the intersection of the benchtop and apron as your datum and measure off this. In some cases it may be necessary to allow extra material on the overhang edge to follow the contour of the basin.

- 1) Invert the basin and align the forward projection with the apron vertical plane and trace around the rim.

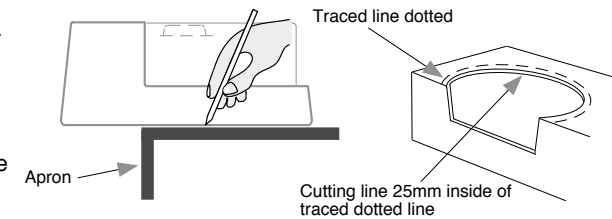

- 2) Mark the cutting line 25mm inside and parallel to the traced line of the basin.

- 3) On the apron, mark cutting lines at a slight angle 115mm down (double check this dimension by measuring off basin).

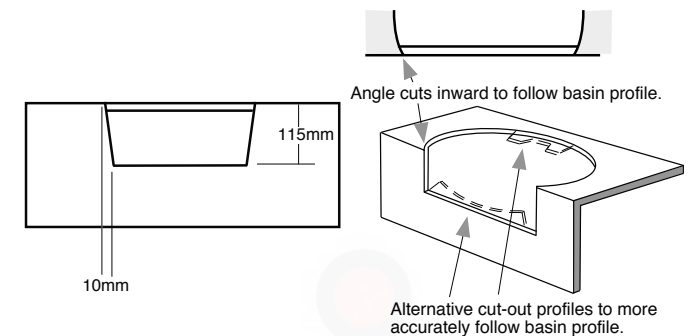

**Notes:**  
 Scale 1:10  
 All dimensions in millimetres.  
 All sizes are nominal.

Vista Sanitaryware  
 Australia Pty. Limited.

Drawing Issue 3-20-8-2009

© Copyright Stowpace P/L 2009

